

INSTALLATION INSTRUCTIONS

PEDIMAT, PEDIMAT AA, & TREADLINE WITH NO FRAME



1.) SITE PREP

- USE WOOD FORMS TO PREPARE A RECESS IN THE CONCRETE A MINIMUM 1/2" DEPTH TO FINAL FINISHED FLOOR SURFACE.
- AFTER CONCRETE HAS CURED, REMOVE WOOD FORMS. (SEE ILLUSTRATION BELOW)
- CLEAN THE CONCRETE RECESS TO REMOVE ALL DIRT, OILY FILMS, AND DEBRIS.



EAGLE MAT
& FLOOR PRODUCTS

932 Hungerford Dr. #37B
 Rockville, MD 20850
 1-877-333-1018

www.eaglemat.com

INSTALLATION INSTRUCTIONS

PEDIMAT, PEDIMAT AA, & TREADLINE WITH NO FRAME



2.) MAT INSTALLATION

- UNROLL THE MAT INTO THE RECESS
- TO ENSURE A PROPER FIT, TRIM THE END VINYL ON THE LEADING AND TRAILING ENDS EQUALLY WITH A UTILITY KNIFE.

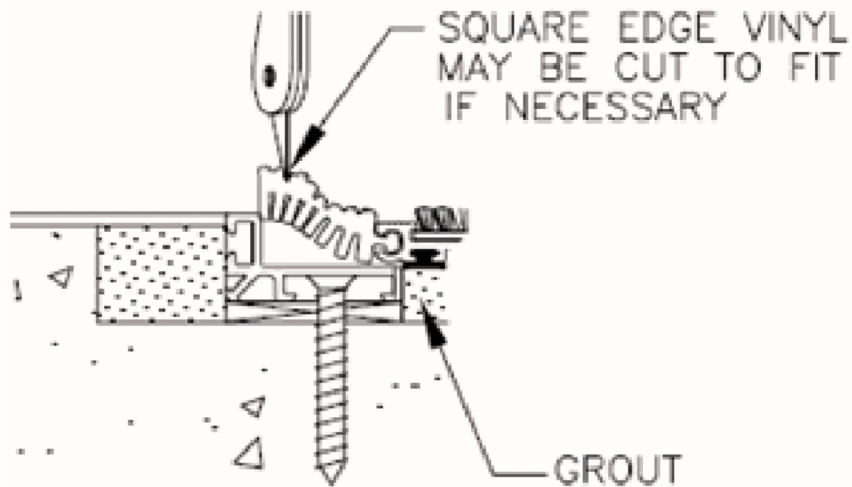

932 Hungerford Dr. #37B
Rockville, MD 20850
1-877-333-1018

www.eaglemat.com

INSTALLATION INSTRUCTIONS

PEDIMAT, PEDIMAT AA, & TREADLINE WITH NO FRAME

3.) COMPLETION

IT IS NECESSARY TO COVER THE INSTALLATION WITH 3/4" PLYWOOD UNTIL ALL ADDITIONAL PROJECT WORK IS COMPLETED. THIS WILL PROTECT THE MAT FROM POTENTIAL ABUSE DURING THE CONSTRUCTION PHASE. DAMAGE OCCURRING FROM INADEQUATE PROTECTION DURING THIS PHASE MAY VOID THE MANUFACTURER'S WARRANTY.

4.) CLEANING AND MAINTENANCE INSTRUCTIONS FOR PEDISYSTEMS

- MANUFACTURER'S SUGGESTED SAFE ROLLING LOAD FOR 350# PER WHEEL.
- HEAVY LOADS BEYOND THIS WEIGHT MAY DAMAGE THE UNITS, CONTRIBUTING TO THEIR PREMATURE FAILURE OR CREATING A TRIPPING HAZARD.
- VACUUM SURFACE REGULARLY WITH BEATER BRUSH ATTACHMENT TO ALLOW CONTACT WITH VARIOUS SURFACES OF ENTRANCE FLOORING.
- BEFORE DEEP CLEANING THE SURFACE, ROLL UNIT BACK TO REMOVE DIRT COLLECTED UNDERNEATH AS NEEDED. DIRT SHOULD BE REMOVED WITH PROFESSIONAL VACUUM CLEANER AND SHOULD NOT BE ALLOWED TO BUILD UP TO THE POINT WHERE A LEVEL MAT SURFACE IS AFFECTED.
- DEEP CLEAN QUARTERLY, EITHER BY REMOVING UNIT TO AN AREA WHERE IT CAN BE CLEANED WITH A POWER WASHER (ON LIGHT SETTING TO AVOID CARPET DAMAGE) OR.
- SHAMPOO THE UNIT IN PLACE (SOAP/WATER EXTRACTION)
- IT IS RECOMMENDED THAT SHAMPOOING TAKE PLACE OVERNIGHT TO ALLOW CARPET FIBERS TIME TO DRY THOROUGHLY BEFORE HEAVY TRAFFIC RESUMES.
- SUGGESTIONS FOR PRE-TREATING THE AREA PRIOR TO SHAMPOOING.
 - REMOVE GUM OR OTHER STICKY SUBSTANCES BY APPLYING A COMMERCIAL FREEZE SPRAY TO THE AFFECTED AREA. THIS SHOULD ALLOW THE RESIDUE TO BREAK OFF EASILY.
 - FOR GROUND -IN DIRT SHOWING IN HIGH TRAFFIC AREAS, ADD ONE CUP OF BLEACH PER GALLON OF WARM WATER AND USE STIFF BRUSH TO PRE-TREAT CARPET FIBERS.
 - IF ALUMINUM NEEDS CLEANED, USE STIFF NYLON BRISTLE BRUSH TO CLEAN WITH SHAMPOO MIXTURE PRIOR TO SHAMPOOING ENTIRE UNIT.
- TO ACHIEVE THE MOST EFFECTIVE SUCTION OF THE SHAMPOOER, RUN THE WAND PERPENDICULAR TO THE RAILS AND NOT ALONG THE LENGTH OF THE CARPET STRIPS.
- TAKE CARE WHEN MOPPING SURROUNDING FLOOR AREA. KEEP MOP AWAY FROM MAT OR GRID. THE AGGRESSIVE TEXTURE OF THE CARPET INSERTS MAY GRAB LINT WHEN THE MOP COMES IN CONTACT, POTENTIALLY CAUSING UNSIGHTLY LINT COLLECTION AT EDGES OF UNIT.
- REPLACEMENT INSERTS ARE AVAILABLE - SEE WWW.PEDISYSTEMS.COM OR CALL 1-570-546-5941 FOR MORE INFORMATION AND FOR CONTACT INFORMATION FOR YOUR LOCAL REPRESENTATIVE.



932 Hungerford Dr. #37B
Rockville, MD 20850
1-877-333-1018

www.eaglemat.com